

SURGICAL ADA SCRUB SINKS

WALL MOUNTED | DWG NO. 05454

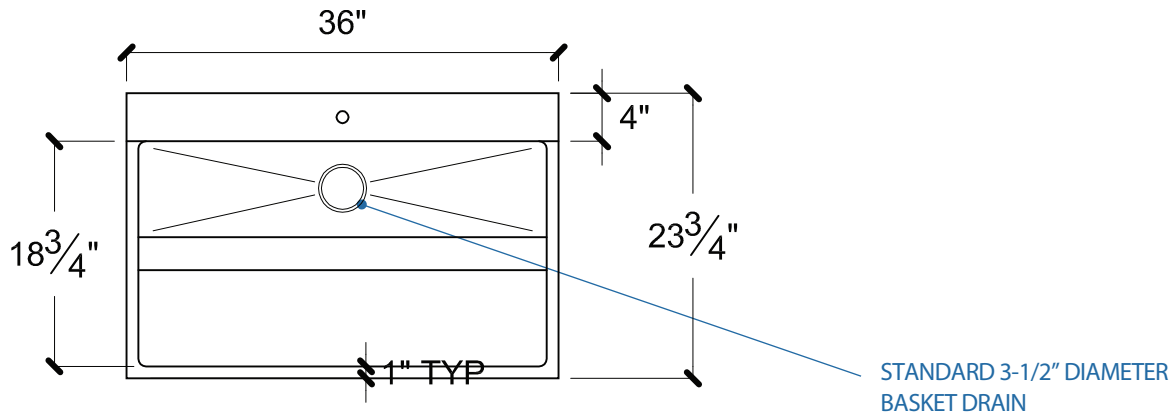
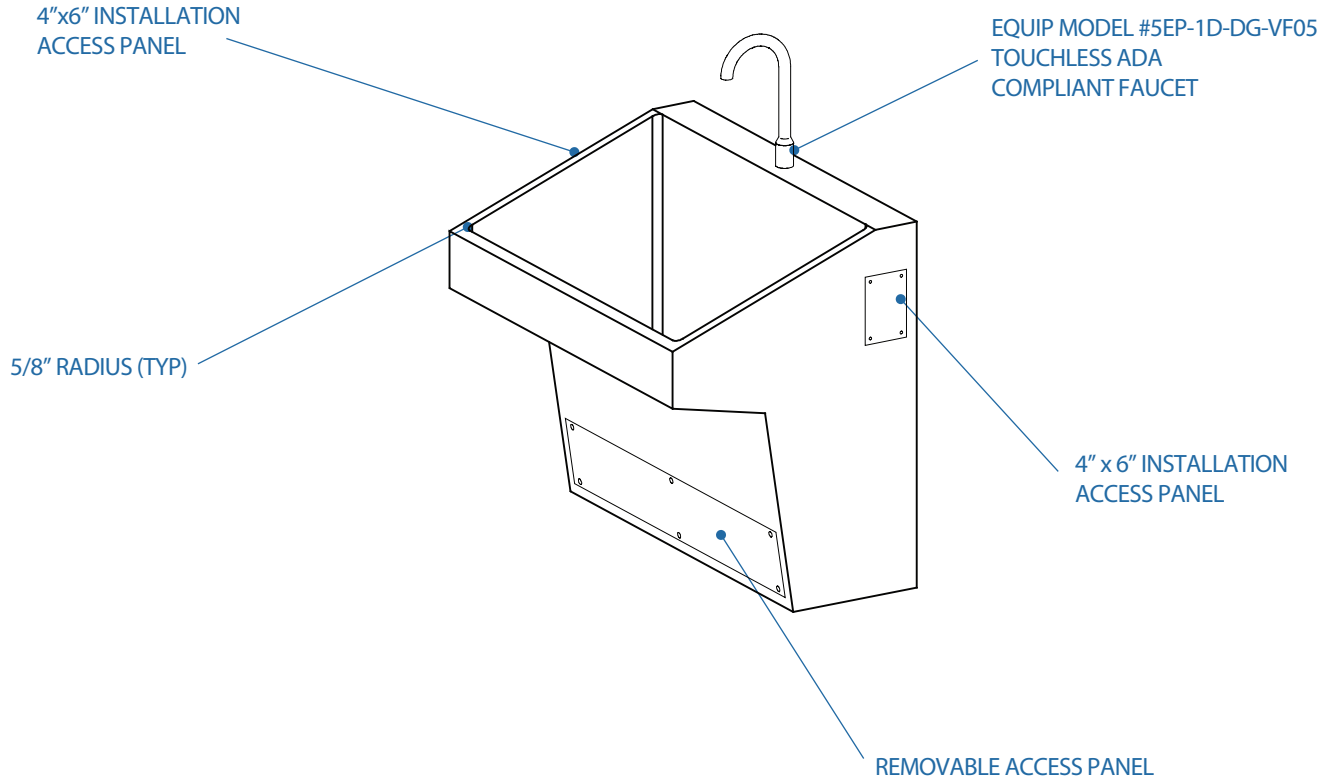

PLAN

SCALE: 3/4":1'

USE FOR ARCHITECT / ENGINEER / CONTRACTOR APPROVAL

Job name _____

Date _____ QTY _____ Contractor _____

Model No. _____ Customer _____ Architect/Engineer _____



Performance Through Stainless!

43 South Linden Ave South San Francisco CA 94080 Ph (650) 589-4231 Fax (650) 589-3981 www.berlinusa.com

SURGICAL ADA SCRUB SINKS

WALL MOUNTED | DWG NO. 05454

T-304 N.S.F.
CONSTRUCTION

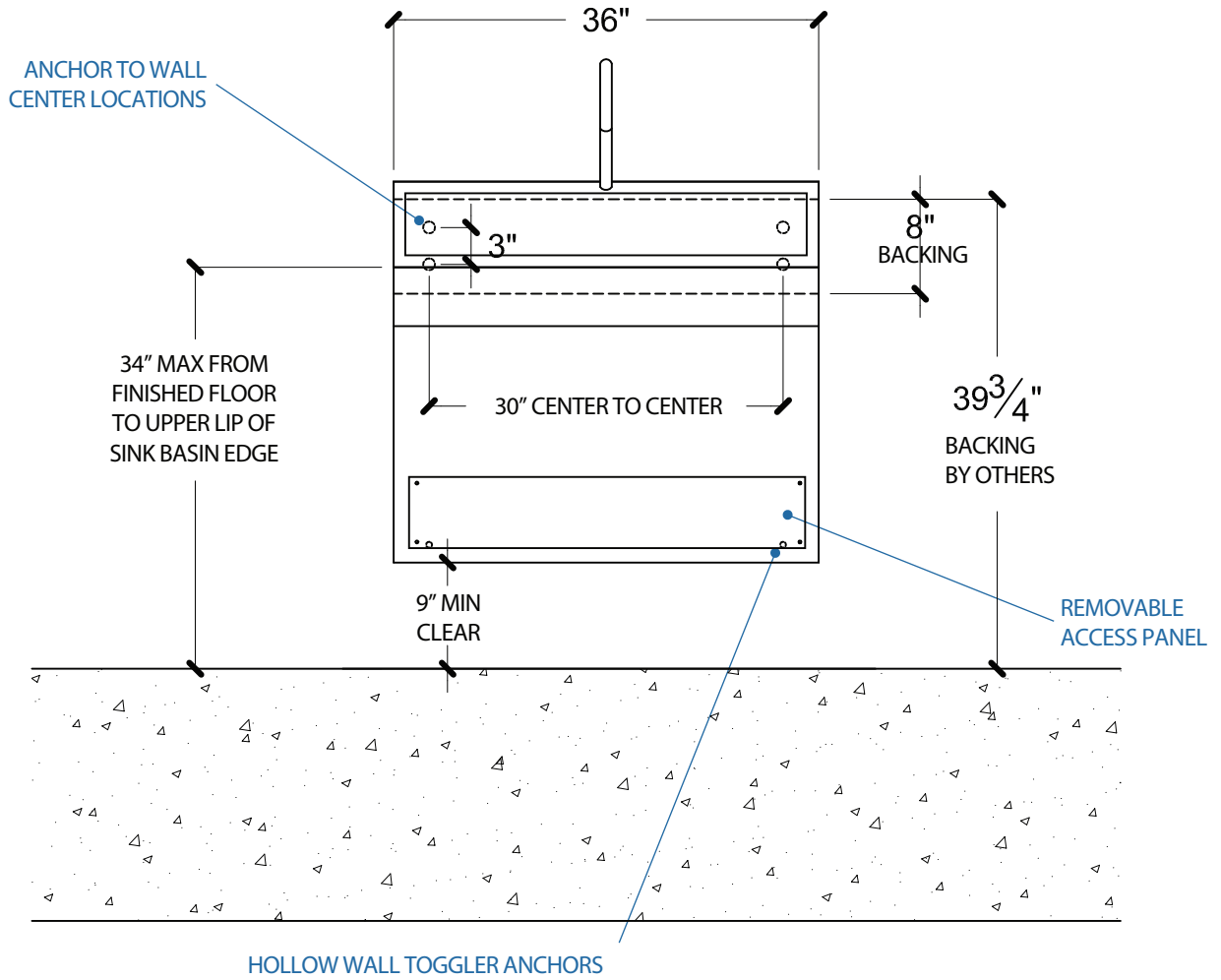

ELEVATION

SCALE: 3/4":1'

OPTIONS	
<input type="checkbox"/>	36" WIDE WITH 1 FACUET
<input type="checkbox"/>	42" WIDE WITH 2 FACUETS
<input type="checkbox"/>	48" WIDE WITH 2 FACUETS
<input type="checkbox"/>	60" WIDE WITH 3 FAUCETS

USE FOR ARCHITECT / ENGINEER / CONTRACTOR APPROVAL

Job name _____

Date _____ QTY _____ Contractor _____

Model No. _____ Customer _____ Architect/Engineer _____



Performance Through Stainless!

43 South Linden Ave South San Francisco CA 94080 Ph (650) 589-4231 Fax (650) 589-3981 www.berlinusa.com

SURGICAL ADA SCRUB SINKS

WALL MOUNTED | DWG NO. 05454

T-304 N.S.F.
CONSTRUCTION

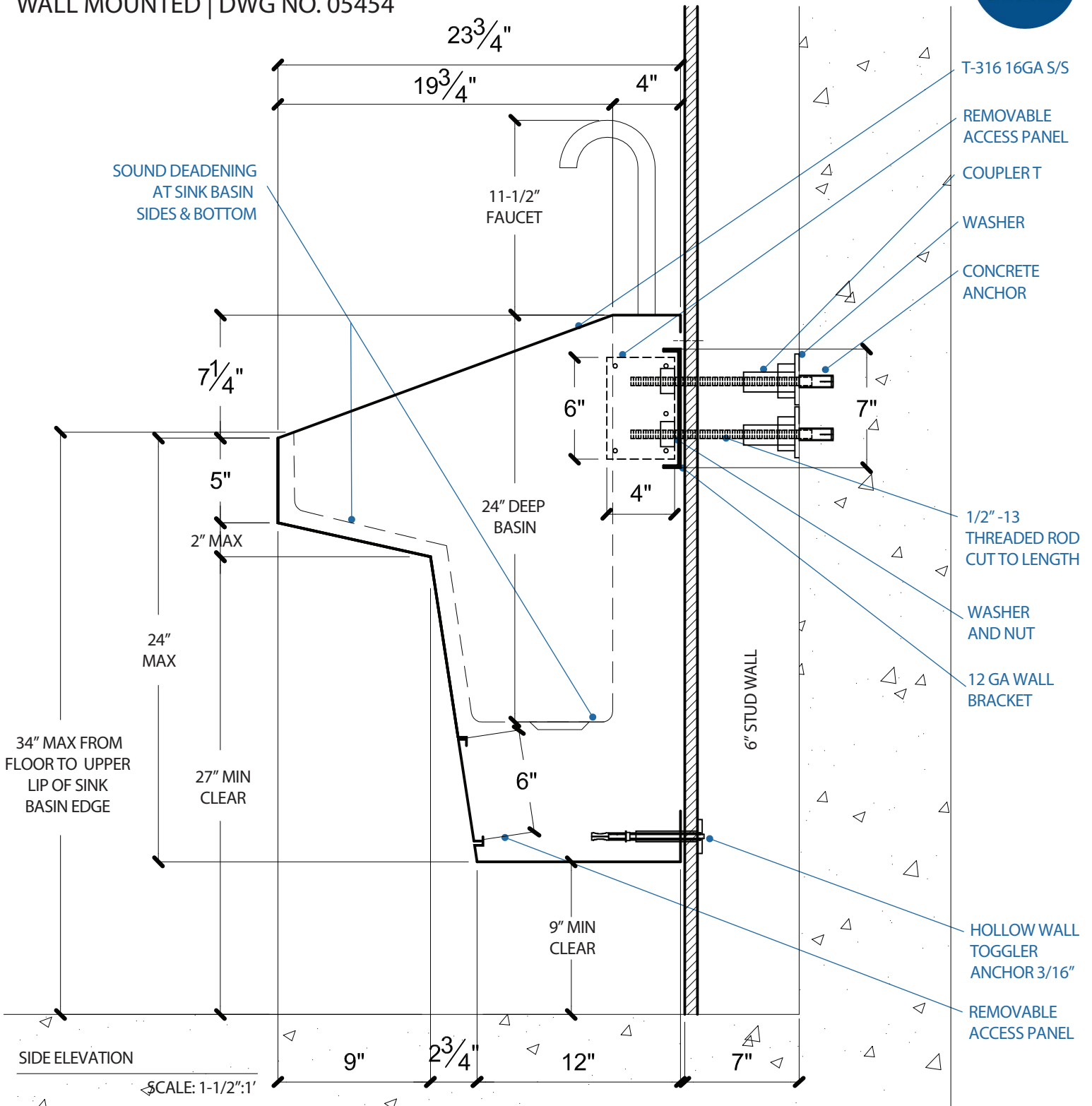

USE FOR ARCHITECT / ENGINEER / CONTRACTOR APPROVAL

Job name _____

Date _____ QTY _____ Contractor _____

Model No. _____ Customer _____ Architect/Engineer _____



Performance Through Stainless!